

The VWT pine marten den box

The Vincent Wildlife Trust, 3&4 Bronsil Courtyard, Eastnor, Ledbury, Herefordshire, HR8 1EP. Telephone +44 (0) 1531 636441 E-mail: vwt@vwt.org.uk

Amendments to the VWT marten den box design, November 2006

Roof/Lid

The shallow sloping roof of these boxes has been designed to be steep enough to shed water whilst remaining horizontal enough to allow easy access to martens (for scattng). However, this feature results in the lid being more difficult to build because of the need to shape the battens. We have considered the option of making the roof completely flat, which would aid construction, as tree trunks are rarely vertical and inevitably the roof will slope to some extent. Having now seen this modification to boxes built by Allan Bantick in Scotland, we feel that it is worth suggesting as an alternative design, especially for small-scale home workshops construction. In this case a piece of bitumastic roofing felt (of the type used on garden sheds) cut to fit and tacked on, could be employed to help with waterproofing. If this modification is used it should be achieved by increasing the height of the front to match the back, with appropriate adjustments to the softwood sides and partitions. The lid itself will need to be slightly shorter from back to front.

Tanalising

Since preparing the specification a new form of Tanalising has become available. The timber we use is protected using Tanalith "C". Our information is that this should now be available only to the professional user. A new treatment, Tanalith "E" is available for the domestic market. This treatment uses modern, environmentally friendly active ingredients and although the working life of Tanalith "E" timber is slightly shorter, it might be a better product to use. Unlike Tanalith "C", there have been no reports of undesirable chemicals leaching from Tanalith "E" treated wood. Another advantage is that a surface colouring compound can be added during treatment and it is possible to buy pre-coloured timber. We have used the dark brown colour on other types of boxes and find it helps disguise them 'on the tree'.

The design offered below represents an attempt to improve on the design of box commonly used for martens. These structures typically are of a relatively large volume, offer little insulation and have a top entrance hole that allows rain to enter and warm air to escape.

The small size of the den cavity in the new design is derived from work done in France on martens using owl boxes (where the smaller boxes were more successful than the larger ones) and also from the average dimensions of a Black woodpecker nest chamber (the main naturally occurring den site for martens in mainland Europe). The front to back distance of only 200mm means that softwood boarding can be employed in the construction, making it similar to a conventional bird bat box. This obviates the need for the complicated frameworks needed for larger structures.

The key features of the new design are:

- Den chamber size is similar to natural den sites
- Good thermal insulation from the use of thick timber and boarding
- Reduced convection heat losses by having entrances at bottom and having a snug fitting lid
- Double ‘chimney’ entrances give den chamber no external corners and so no rain penetration, increases insulation for the central chamber and gives animals a choice of entrance (mimicking many natural tree cavities)

Materials

The plywood used for the front, back and lid is 18mm exterior WBP (water and boil proof) grade. The glues used in its construction are weatherproof, but the timber still needs to be painted and exposed edges need particular attention. Marine grade plywood would be better but is extremely expensive. The sides (both inner and outer) are cut from what is sold as 200mm x 25mm rough sawn timber, although the actual thickness of the timber may vary slightly and allowance for this should be made. The timber we use tends to be closer to 23mm thick. The timber for the battens on the underside of the lid needs to be cut with an angle of 10.5° on the joining edge. In fact these battens can be cut as a pair from a single piece of c100mm wide softwood. The battens for the side should be cut to match these battens. These lid battens are generally cut from larger timber to suit the requirements. The exact dimensions are not critical as long as the fit is good. It might be necessary to make the lid panel slightly larger (or smaller) to suit the size of battens available.

All our softwood was CCA pressure treated (e.g. “Tanalith” or “Tanalised”), which gives a life expectancy of c30 years. There has been concern over the possible leaching of copper, chrome and arsenic compounds for such timber, so well weathered supplies should be sought.

Construction

The boxes are fixed together using good quality galvanise screws. Screws do not suffer from the problems of ‘nail creep’ caused by expansion and contraction, which can cause the parts of nailed boxes to separate, letting the weather in. It is possible that ribbed nails delivered from a nail gun would be as effective as screws but we have not tried this.

The method of construction is fairly straightforward:

Screw the rear battens to the back panel from what will become the inside of the box

Screw the four sides to the back, making sure that the widths of the chimneys and den chambers are correct. Marking out the back panel with pencil lines and then pre-drilling the screw holes can help here. For making a larger number of boxes, it may be better to construct some appropriately-sized 'spacers' and then clamp all four side together using sash cramps. Remember that the inner sides are shorter, allowing the bottom to be recessed.

Screw the front panel to the sides

Fit the bottom, making sure that it is well recessed to prevent rain driving in, and fix firmly with screws. It might be prudent to leave cutting the floor until this stage, so that any slight variations in width of the box can be accommodated.

Screw the rear batten to the underside of the lid. Test fit this onto the box and scribe line to show the position of the front and sides of the box using a pencil. Fit the remaining battens, ensuring that the fit on the box is snug. (Again, it might be prudent to leave cutting the lid panel until this stage, so that any slight variations in the box size can be accommodated. A well equipped workshop making good numbers of these boxes is likely to be able to produce them to much closer tolerances and such problems are unlikely to occur.)

Drill pilot holes through the middle of each side batten into the top edge of the outer side for a fixing screw. As you may wish to remove these for occasional inspections, we recommend using stainless steel screws here, as galvanised ones can seize in the wood and be impossible to remove.

Finishing

If CCA treated, the softwood needs no other treatment, but the plywood should be given two or three coats of exterior wood coating. Use the low odour water-based varieties that are designed for garden furniture, sheds, fences etc. pay particular attention to exposed plywood edges and the lid, which will have to contend with slow draining water (and hopefully marten scats!) When dry, we suggest that each box is has a unique number painted on the front.

Erecting

We fit these boxes on trees at a height of c4m, out of the way of ground-based predators and inquisitive people. Once a tree has been selected, two wooden battens (25mm x 50mm CCA treated softwood) should be nailed vertically to the horizontal battens on the rear of the box. These should be spaced so that they just keep the horizontal battens off the trunk. The length of these is unimportant as long as they reach between the horizontal battens.

Plan view of vertical batten arrangement

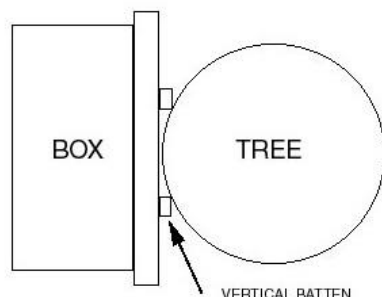

The boxes are heavy (c.13kg or c.29lbs) and we strongly recommend the use of a simple rope strap and pulley arrangement so that a person on the ground can haul the box to the correct height. Using a ladder, a second person can then complete the fixing. Three loops of wire line are wrapped horizontally around the tree and box (fitting them under the protruding top batten) and then knotted off. We use best quality steel-stranded, plastic-coated washing line. Pulling downwards on the top of the box will cause it to jam firmly against the trunk.

Inspecting

Disturbing pine martens and their dens in Britain requires a licence from the appropriate statutory nature conservation organisation. We recommend checking for signs of occupancy of boxes by pine martens by looking for the presence of marten scats on the box lid from a distance of at least 20m. This should obviate the need for a licence and, done quietly and infrequently (maximum twice per year), should avoid disturbance that might lead a pine marten to desert the box.

Under licence we have used an endoscope (J W Allen - ProVision 100) to view the nest chamber through a 13mm diameter hole bored in an outer side opposite the cut-out in the inner side. This hole can be sealed with a small rubber bung or similar when not in use. We recommend temporarily blocking the entrance next to the observer when carrying out endoscopic inspections, to avoid coming into contact with any escaping animal. Removal of the lid should not be undertaken as part of any routine monitoring work. Even endoscopic inspection may result in enough disturbance to cause any resident pine marten to relocate.

This design appears to be less attractive to non-target species than older designs, and we have yet to find squirrels and birds using the den chamber. However, colonies of honey bees *Bombus* spp. may adopt these boxes so care needs to be taken during inspections.

Maintenance

The box should require only basic maintenance. Check the attaching line to make sure that the tree is not growing into it. Just moving it slightly every few years might be enough to prevent this happening. The box will also require repainting every three years or so. Installing one of these boxes represents a considerable investment of money, time and effort, so it makes sense to maximise their life by proper care. Unfortunately there may not be a time of the year when pine martens can be guaranteed to not be in residence. However, September and October are probably the safest months to repaint, again using a low odour coating. Check for occupants first. It might be easiest to lower the box to the ground for painting.

Suggestions for choosing sites to install the VWT marten den box

The den boxes are likely to produce greatest benefits, in terms of improved habitat quality for pine martens, if they are installed in large, undisturbed, prey-rich woodlands where natural den sites such as tree cavities are scarce or absent. Commercially managed woodland, or unmanaged woodland dominated by trees of less than 100 years old, is likely to be suitable provided there is adequate prey and freedom from excessive disturbance or risk of persecution. Extensive, diverse woodlands and/or woodlands with good habitat links to other woodland are preferable to small, monocultural and/or isolated woodlands. Within suitable woodland, trees for attaching boxes should be selected carefully to minimise the risk of interference or disturbance. For example, choose trees out of sight of public roads or footpaths and away from areas targeted for woodland management or harvesting in the near future. Boxes sited in areas of woodland that is diverse (in terms of structure, topography or species composition) may be more attractive to pine martens than those in monotonous areas. Finally, when choosing a site for a box, bear in mind the future requirement to view the lid of the box through binoculars to check for signs of marten scats (see below).

Suggested minimum densities at which boxes should be installed

In order to achieve the intended habitat improvements, in terms of increased availability of marten dens suitable for breeding (and to maximise the chances of pine martens finding the boxes), we recommend spacing boxes evenly within the woodland at a minimum density determined by the nature of the woodland habitat. Our aim is to achieve a density that provides a minimum of four boxes within a typical female pine marten home range. Since female home range sizes vary in relation to woodland type, we suggest the following guidelines:

<i>Woodland Type</i>	Minimum density of marten boxes (no. per square kilometre)
Lowland, species-rich, broadleaved or mixed	4
Lowland, commercial, mixed coniferous	2
Upland, commercial, coniferous	1

The VWT pine marten nest box database

We are keen to encourage others to establish their own den box schemes and to contribute their results and observations to a central database. The VWT has established such a database and we would be pleased to receive your findings. We aim to produce a regular news sheet for all those participating – and of course, all data will remain the property of the contributors. We feel that collectively we might be able to assess the value of these boxes as a habitat enhancement tool for the species in marginal areas. A sample recording form is attached. We look forward to hearing from you.

John Messenger & Johnny Birks - 29th June 2004

Pine Marten Box Monitoring

Site Box #

Recorder Date

Number of scats	Below box		On roof	
Internal inspection by endoscope? Result?				
Internal inspection by lid removal?		Number of martens seen		
Evidence of breeding?				
Other field signs?				
Condition of box (e.g.damp)				
Other comments				

Site Box #

Recorder Date

Number of scats	Below box		On roof	
Internal inspection by endoscope? Result?				
Internal inspection by lid removal?		Number of martens seen		
Evidence of breeding?				
Other field signs?				
Condition of box (e.g.damp)				
Other comments				

Construction plan

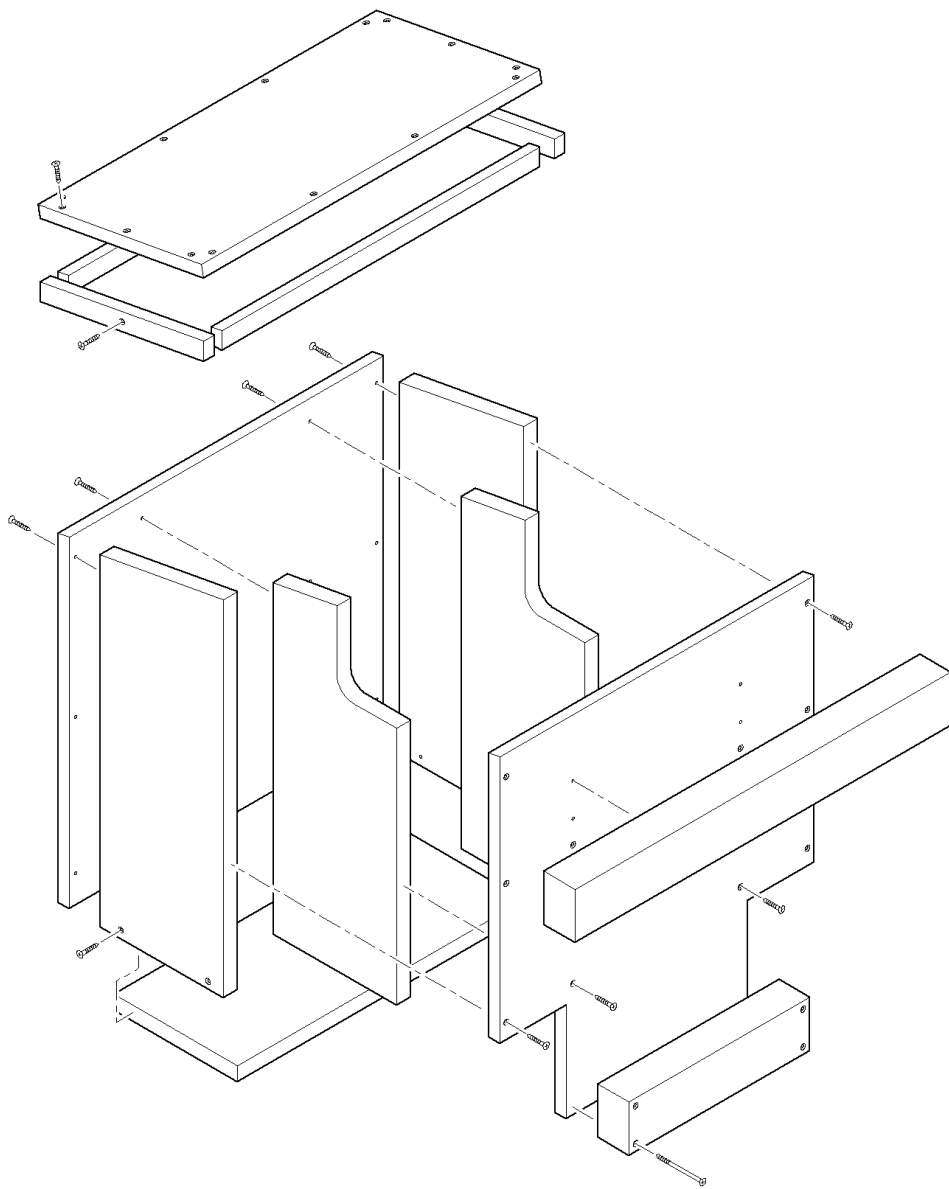

Cutting plan

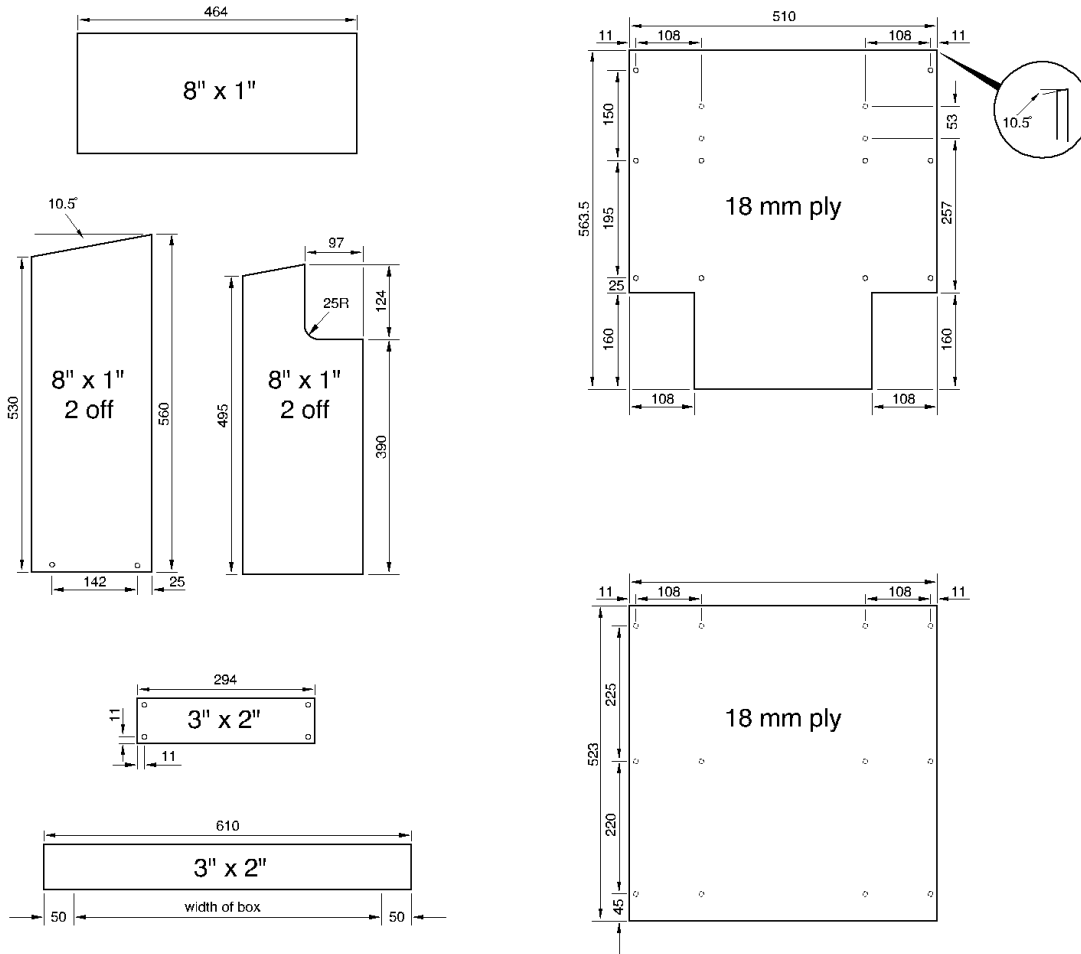

Box Parts

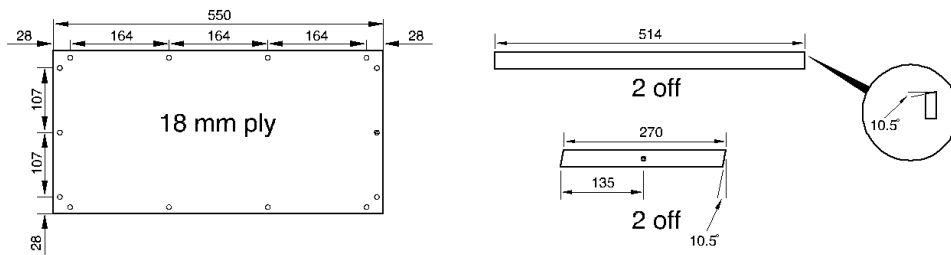

Lid Parts

All dimensions in mm
Countersink fixing holes